

# ACSA Design-Build Award

---

2015-2016 Winner Submission Materials

Lamar Station Classroom for Urban Farming

RICK SOMMERFELD

University of Colorado Denver

# LAMAR STATION

## A CLASSROOM FOR URBAN FARMING

The design-build studio at [name withheld] focuses on layering the principles of program, structure, material, context, environment, and light into a clear architectural design solution. Throughout the semester the students identified collaborative partners to work with them as an interdisciplinary integrated project delivery team.



## PROJECT OVERVIEW

Lamar Station Crossing is a new development by Metro West Housing Solutions, the housing authority of Lakewood, CO. The PUD is adjacent to the newest light rail line in Colorado, the W line to Golden. The housing authority approached [name withheld] about designing a classroom to educate the residents of this new development about urban farming, environmental education and provide space for youth programs.

The site for the classroom is in the panhandle of the property along the Lakewood Gulch. The surrounding neighborhood is considered “transitional,” but is being revitalized by the new transit-orientated development. On the other side of the Lakewood Gulch is a Head Start program. Metro West Housing donated the land for the facility and installed a core-ten bridge over the gulch. The bridge allows children, and their families, direct access to the Lamar Station property and the light rail station. It also helps keep pedestrian traffic to the light rail stop off the streets that coincidentally don’t have any sidewalks.



figure 1. *Lakewood Gulch*

figure 2. *Core-ten bridge to the Head Start program*

figure 3. *View of the classroom from the bridge*

## PRE-DESIGN: MATERIAL SKIN

The objective of the pre-design phase of the studio is to identify, in the design brief, an impetus for the project. In the Lamar Station project, the students found an interesting contextual dichotomy while interviewing the client. Because the sidewalk from the Head Start program came within ten feet of the proposed classrooms site, Metro West requested that the structure have an opaque wall to preserve the privacy of the classroom near the path. They also suggested the structure maintain a clear sightline from the classroom to their main office located over 300 feet away. The transparency of the sightline and opacity of the wall were in direct conflict. The transparent opaque wall became the major design driver for the first integrated project delivery meeting. It led to a material and structural discussion that would last nearly half the semester.

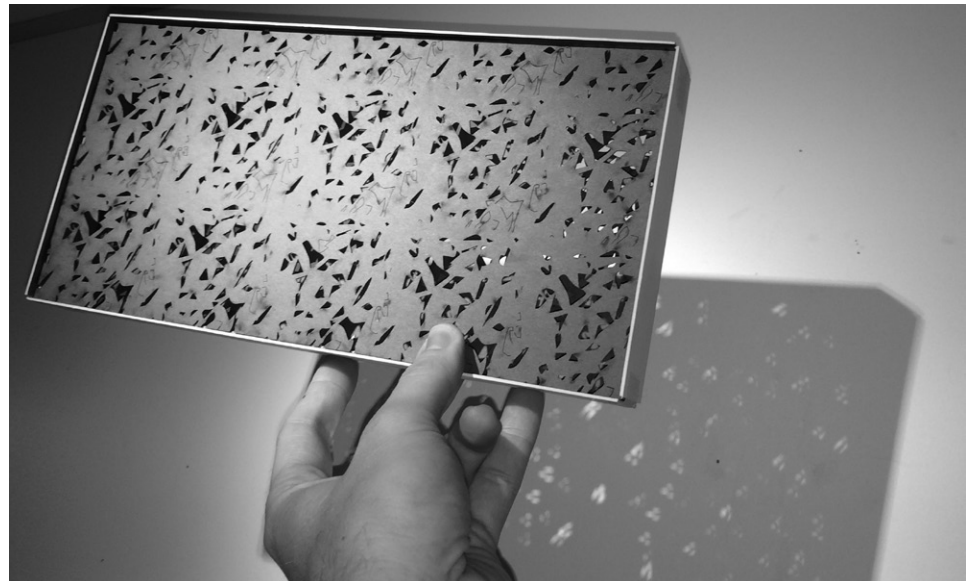
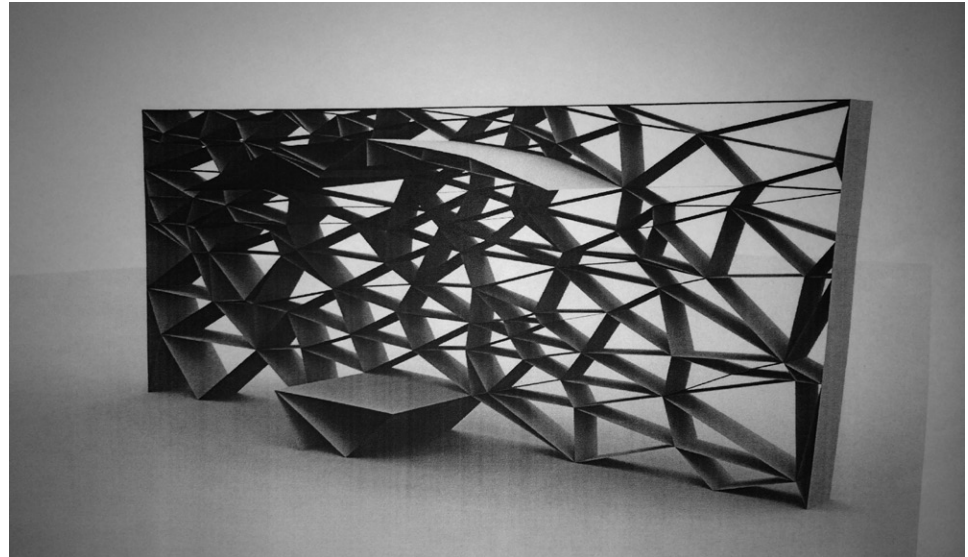

figure 4. *Skin study*  
figure 5. *Skin study*

## SCHEMATIC DESIGN: PROGRAM + CONTEXT + ENVIRONMENT

While the students continued to study and explore the transparent/ opaque wall they simultaneously studied the relationship between program, context, and environment. In teams of three to four the students produced a series of design proposals for review with the client and integrated project delivery team. At the conclusion of every review, the team selected the design that best solved the program, context, and environmental requirements. The selected project was then turned over to the entire studio for redevelopment. The objective is to clearly synthesize the requirements of the design proposal into a singular architectural vision. This iterative process helps clarify the project while removing authorship from a single student or student group.

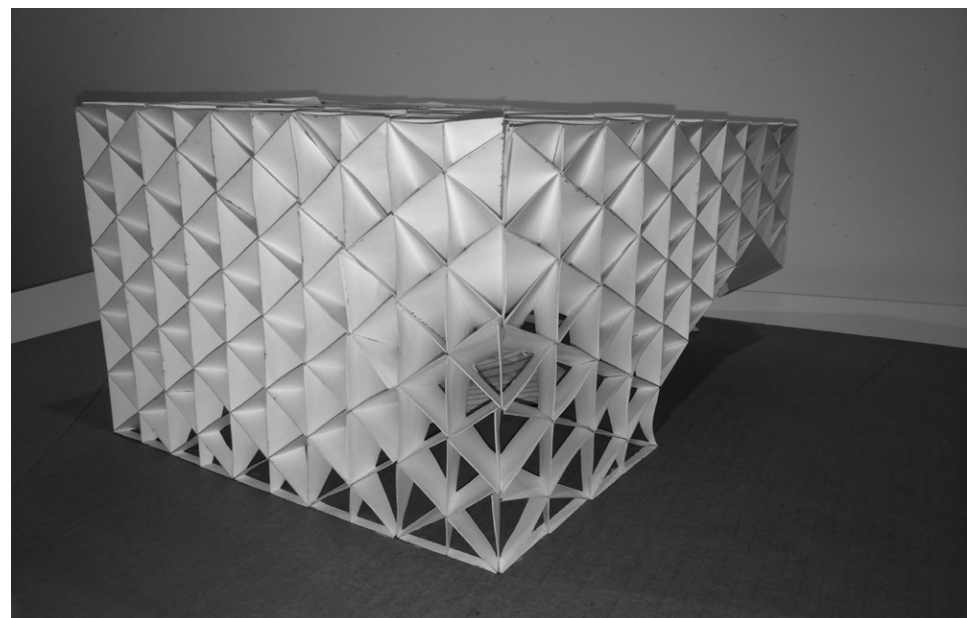
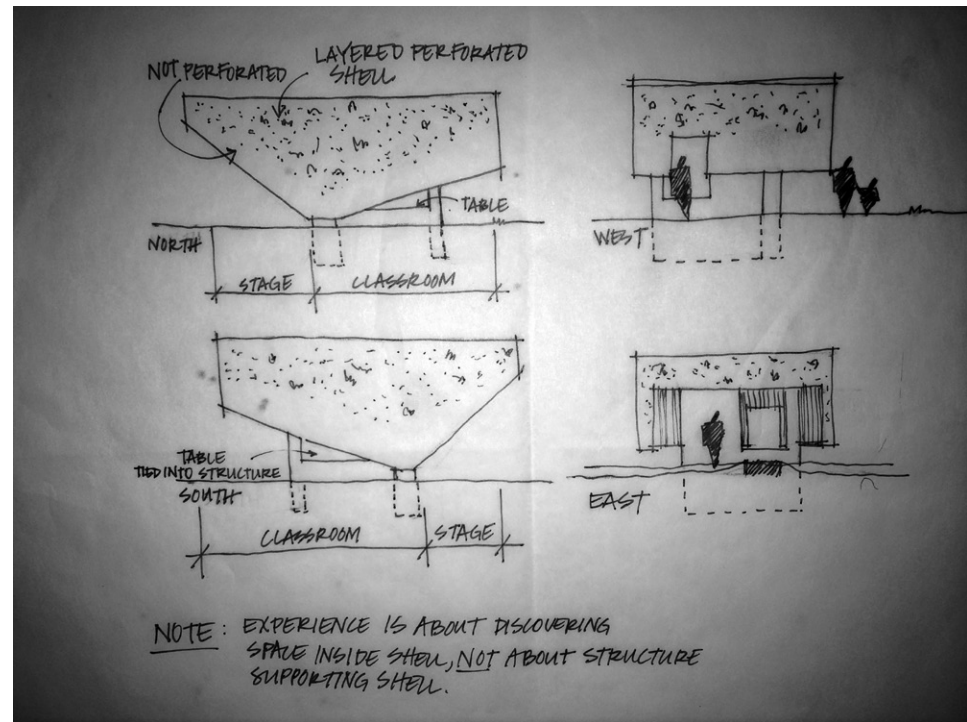
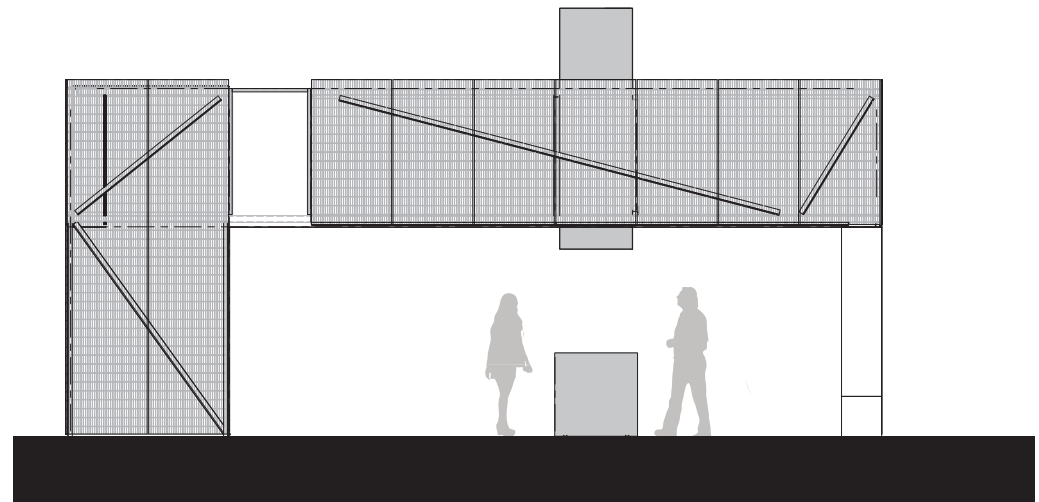

figure 6. Student design proposal  
figure 7. Student design proposal

## DESIGN DEVELOPMENT: STRUCTURE AS SKIN

The objective of the design development phase was to reconsider the project through the lens of structure, materiality, and light. By studying Lean Project Delivery methods, the students asked questions about how to optimize their design. What elements could be combined to create a more clear solution? What dimensions did the proposed materials come in and how could those proportions become the grid for the design itself? As more questions were asked and solutions were proposed the structural engineer noted that the use of bar grate as cladding would likely allow for some of the load to be carried by the skin. This one comment radically changed the entire semester. By the end of the studio session, the students concluded that a new proposal was required, one that reconsidered all the relationships that had been established.



SOUTH ELEVATION

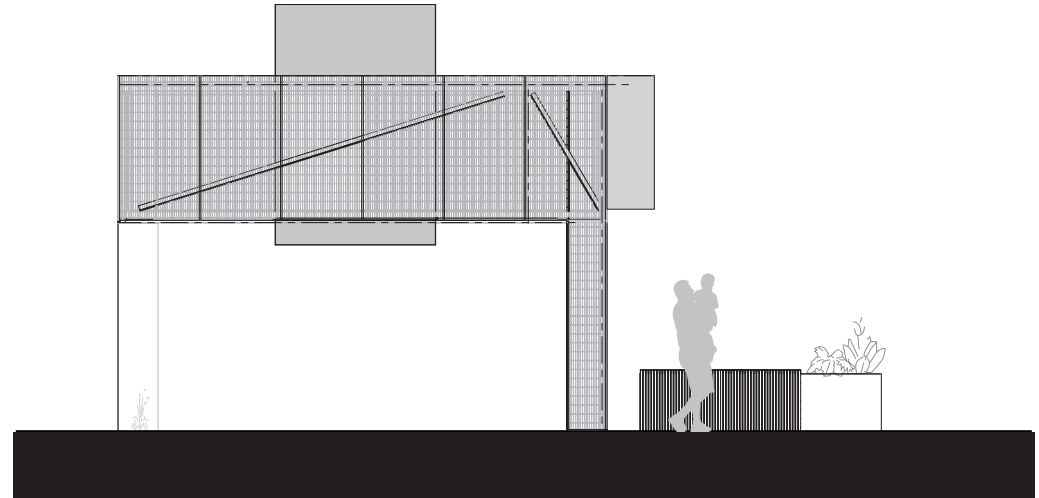

WEST ELEVATION



figure 8. *South elevation*  
figure 9. *West elevation*

**REDESIGN:**  
 STRUCTURE + MATERIAL =  
 PROGRAM, CONTEXT, ENVIRONMENT AND LIGHT

Optimization became the operative word in the redesign of the project. The separation between skin and structure no longer existed. The steel bar grate was used to carry vertical loads and eliminated the vertical webbing in all the trusses. Interior trusses were re-designed to reflect the programmatic requirements of the space. Light wells, gutters, and ceilings were used as the structure. The steel plate that linked the interior and the exterior wall became a shear wall to handle the lateral loads. The project became much clearer, and in the process more transparent. By eliminating excessive layering, the students saw the beauty of a structural expression reinforcing their architecture.

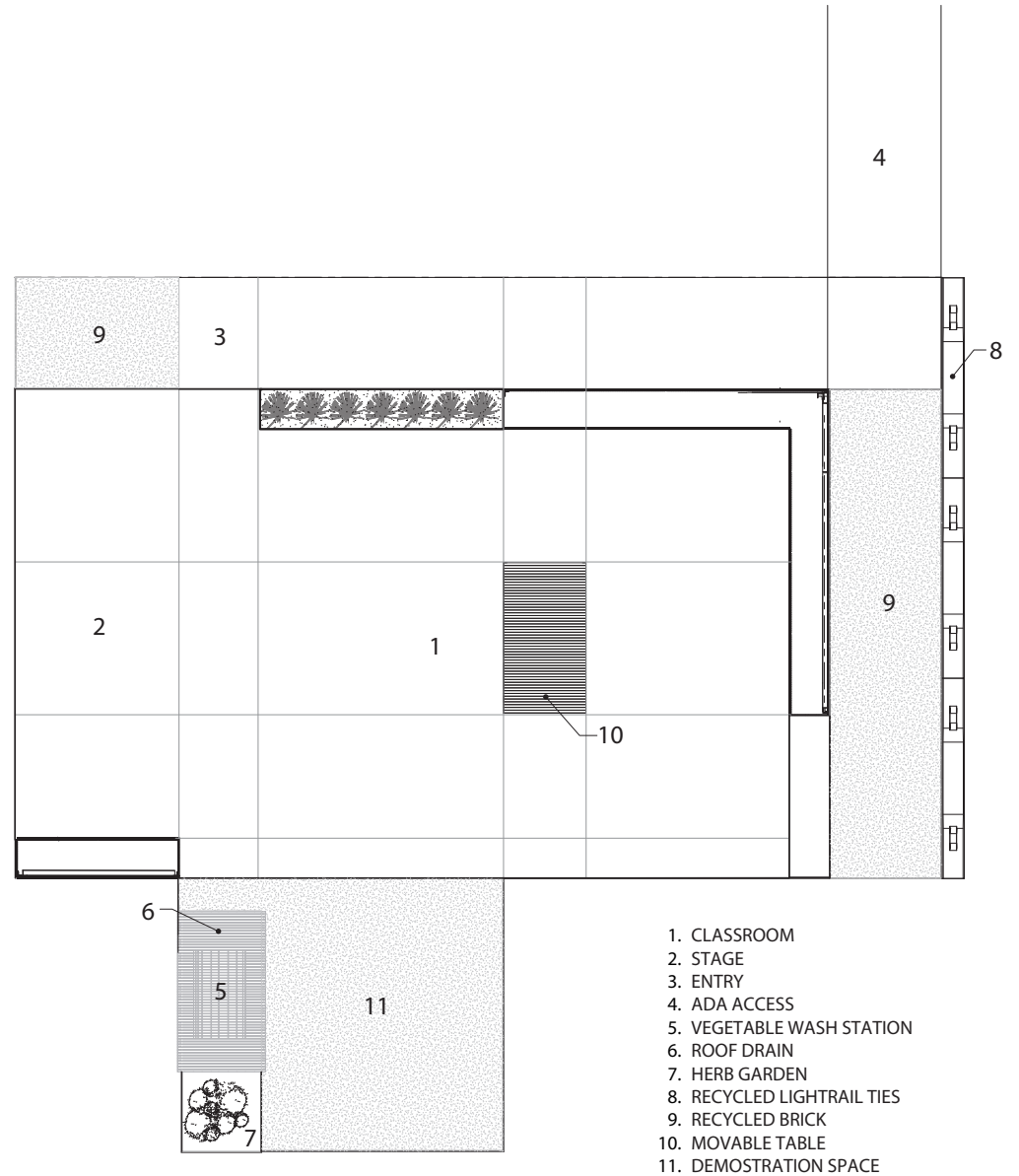

figure 10. Floor plan

FLOOR PLAN



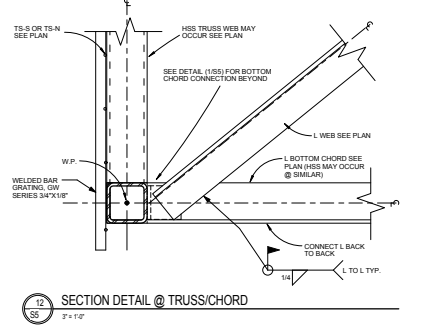
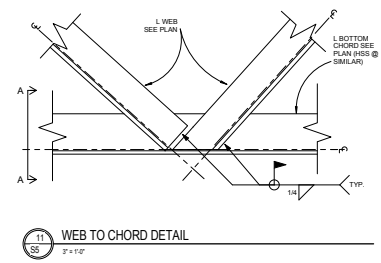
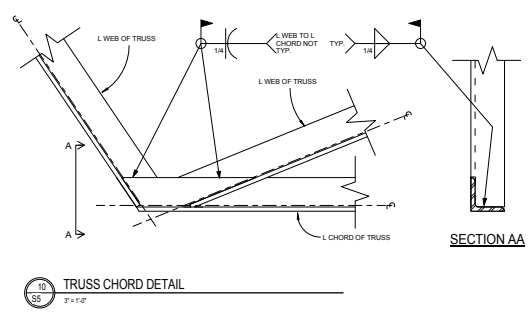
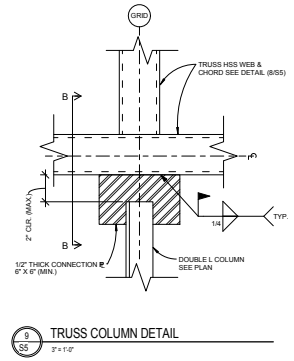
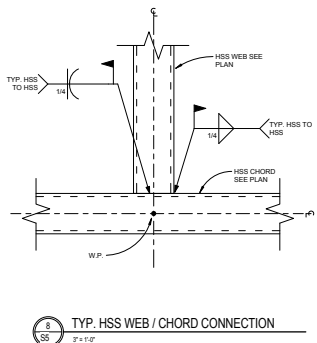
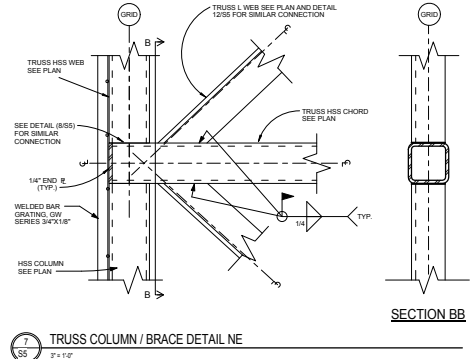
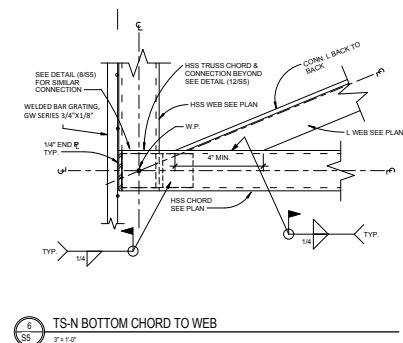
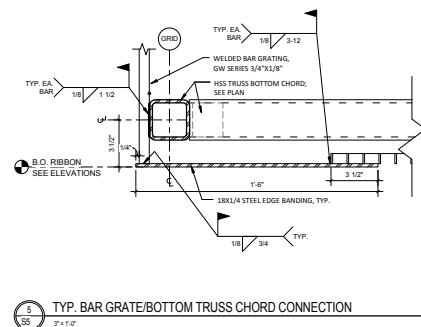
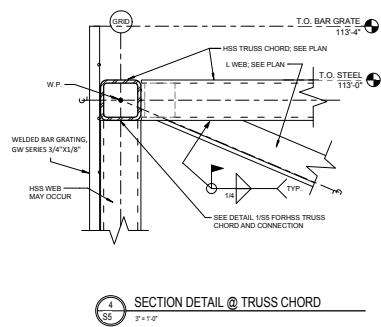
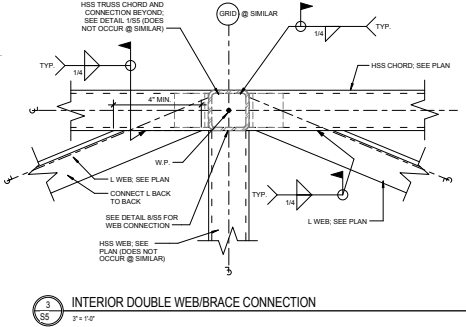
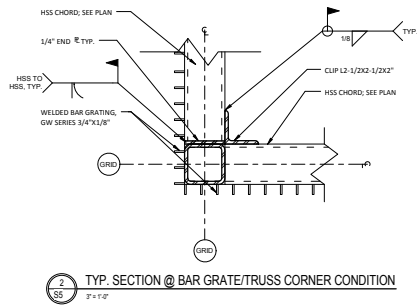
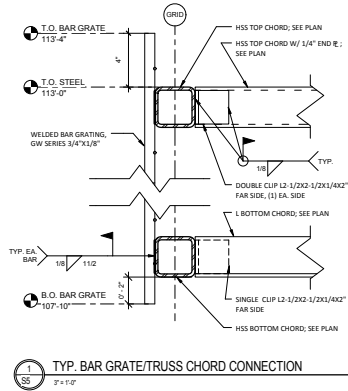

figure 14. Student's structural drawings of steel connections.





figure 11. *Opacity of the skin from the path*

figure 12. *Transparency of the skin as viewed from the Metro West office*



figure 13. *Entry looking down the gutter to the wash station and herb garden. The steel plate of gutter carries the load of the roof.*



figure 15. *Students finishing the concrete slab.*  
figure 16. *Students working on the mat foundation.*



figure 17. Steel bar grate mock-up on the finished mat foundation.  
figure 18. Student sketches on the steel ensuring the proper structural work points during steel fabrication.



figure 19. *Students fabricating and welding the steel canopy on the ground.*  
figure 20. *Craning the canopy into place.*



figure 21. *Recycled concrete railroad ties as a bench/ retaining wall.*  
figure 22. *Students working on the steel bar grate furniture.*



*Looking northeast. The "entry gutter" drains into the wash station. The water from both drain into the herb garden watering the herbs throughout the year. The core ten bridge to the Head Start program can be seen in the distance.*



*Interior looking at the mobile classroom table. The steel plate on the left wall acts as the shear wall for the structure. The steel oculus helps carry the load of the truss by reinforcing the truss webbing. Lakewood Gulch, and the future Lakewood Gulch River Trail, are on the right.*





*Looking northeast through the cantilever. The Metro West Housing development is in the background .*



*Looking southeast.*